

# CLUMP

## Tank Washing Nozzles

### DESIGN FEATURES

- Each nozzle in the stationary cluster is a BETE clog-resistant full cone nozzle of the MaxiPass® series
- Can be supplied with various other BETE nozzles for any desired application
- Female connection

### SPRAY CHARACTERISTICS

- Spherical omnidirectional coverage
- Six nozzles arranged in cluster to project spray in all directions

**Flow rates:** 28.1 to 290 l/min  
(Special flow rates available)

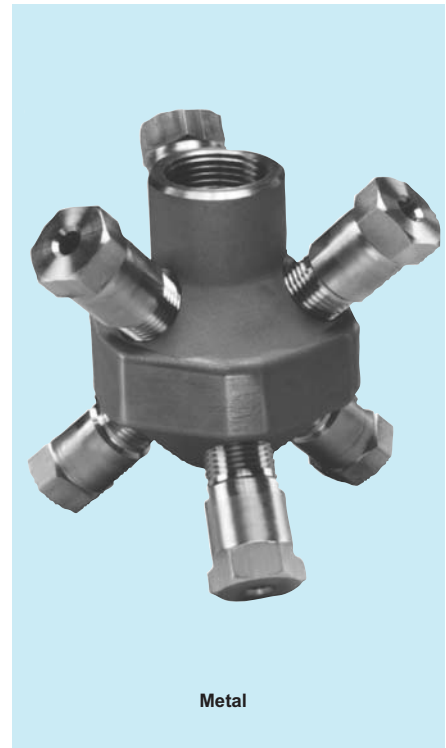

Metal

### CLUMP Coverage Chart When spraying at 3 bar

Female Pipe Size	Nozzle Number	Scrubbing Diameter (mm)	Rinsing Diameter (mm)
3/4"	CLUMP125	1200	2400
	CLUMP156	1200	3700
	CLUMP187	1800	4300
1"	CLUMP187	1800	4300
	CLUMP218	2400	4300
	CLUMP250	3000	4900

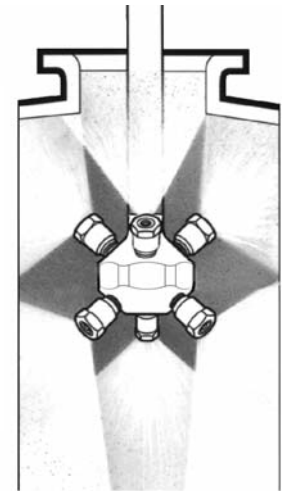
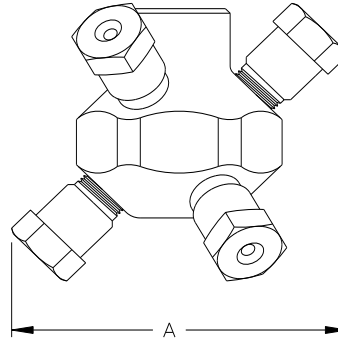

Typical CLUMP installation

Dimensions are approximate. Check with BETE for critical dimension applications.

### CLUMP Flow Rates and Dimensions

Spherical, 360° Spray Angle, 3/4" and 1" Pipe Size, BSP or NPT

Female Pipe Size	Nozzle Number	K Factor	LITERS PER MINUTE @ BAR						Minimum Entrance Opening (mm) A	Weight (kg)	
			0.7 bar	1 bar	2 bar	3 bar	4 bar	5 bar		Metal	Plas.
3/4"	CLUMP125	33.2	28.1	33.2	46.0	55.6	63.7	70.8	120	1.29	0.22
	CLUMP156	52.7	44.6	52.7	73.2	88.2	101	112			
	CLUMP187	76.2	65.7	76.2	106	128	146	163			
1"	CLUMP187	76.2	65.7	76.2	106	128	146	163	146	2.34	0.40
	CLUMP218	121	103	121	168	203	232	258			
	CLUMP250	136	115	136	188	228	261	290			

$$\text{Flow Rate (l/min)} = K (\text{bar})^{0.47}$$

**Standard Materials: 316 Stainless Steel.** Other materials available on request. 3/4" CLUMP not available in PTFE.

Spray angle performance varies with pressure. Contact BETE for specific data on critical applications.