

# EZ TF WT

## EZ Quick Change Connection System

### DESIGN FEATURES

- Nozzles can be changed in seconds without tools
- Three part nozzle, base, gasket and interchangeable tip
- Exclusive ramped engagement for efficient automatic alignment
- Threaded adapters will accommodate other standard BETE nozzles. Shut-off pumps are also available

### SPRAY CHARACTERISTICS

- Available in six standard tips: EZTF; EZWL; EZWT; EZFF; EZNF; EZSPN

#### More EZ tips:

- Full Cone: page 30
- Flat Fan: pages 66 and 67

#### Flow rates: 0.13 to 206 l/min

#### Spray Angles:

- EZTF: 60°, 90°, 120°, and 180°
- EZWT: 70° and 110°



EZTF

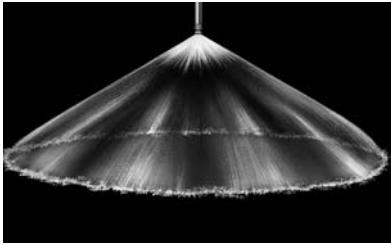

120° Hollow Cone

Dimensions are approximate. Check with BETE for critical dimension applications.

### EZTF Flow Rates and Dimensions

Hollow Cone Spiral 60° (V), 90° (M), 120° (W), 150°, 170° or 180° (XW) Spray Angle 1/8" to 1/2" BSP or NPT

Pipe Size	Nozzle Number	K Factor	LITERS PER MINUTE @ BAR												Approx. Orifice Dia. (mm)	Approx. Assembly Dim. (mm)		Wt. (g)	
			0.3 bar	0.5 bar	0.7 bar	1 bar	2 bar	3 bar	5 bar	7 bar	10 bar	15 bar	20 bar	30 bar		Hex Length			
1/8"	EZTF6	3.19	1.75	2.26	2.67	3.19	4.51	5.53	7.13	8.44	10.1	12.4	14.3	17.5	2.38	1/8"	22.4	41.4	62
	EZTF8	5.93	3.25	4.19	4.96	5.93	8.38	10.3	13.2	15.7	18.7	22.9	26.5	32.5	3.18				
1/2"	EZTF10	9.12	4.99	6.45	7.63	9.12	12.9	15.8	20.4	24.1	28.8	35.3	40.8	49.9	3.97	1/4"	22.4	44.5	62
	EZTF12	13.7	7.49	9.7	11.4	13.7	19.3	23.7	30.6	36.2	43.2	53.0	61.1	74.9	4.76				
1/4"	EZTF14	18.5	10.1	13.1	15.4	18.5	26.1	32.0	41.3	48.8	58.4	71.5	82.6	101	5.56	3/8"	22.4	46.0	74
	EZTF16	24.2	13.2	17.1	20.2	24.2	34.2	41.8	54.0	63.9	76.4	93.6	108	132	6.35				
1/2"	EZTF20	37.6	20.6	26.6	31.5	37.6	53.2	65.1	84.1	99.5	119	146	168	206	7.94	1/2"	22.4	47.5	82

Flow Rate (l/min) =  $K \sqrt{\text{bar}}$

TF20 not available with 1/8" base

Standard Materials: Brass, Viton and Buna-N gaskets standard. 316 Stainless Steel available upon request.

Spray angle performance varies with pressure. Contact BETE for specific data on critical applications.

TO ORDER: specify pipe size, connection type, nozzle number, spray angle, and material.

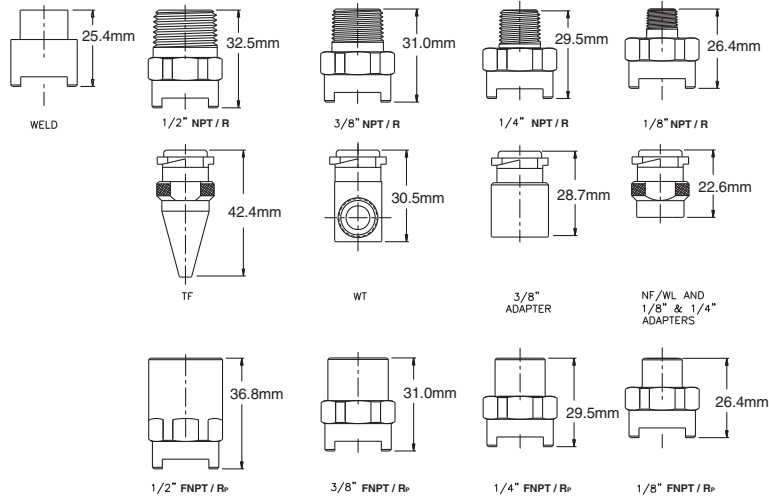

Dimensions are approximate. Check with BETE for critical dimension applications.

### EZWT Flow Rates and Dimensions

Hollow Cone, Narrow (70°) and Wide (110°) Spray Angles 1/8" to 1/2" BSP or NPT

Pipe Size	Nozzle Number	K Factor	LITERS PER MINUTE @ BAR												Orifice Dia. (mm)	Approx. Assembly Dim. (mm)		Wt. (g)	
			0.3 bar	0.5 bar	0.7 bar	1 bar	2 bar	3 bar	5 bar	7 bar	10 bar	15 bar	20 bar	30 bar		Hex Length	Hex Length		
1/8"	EZWT10	0.228	0.13	0.16	0.19	0.23	0.32	0.40	0.51	0.60	0.72	0.88	1.02	1.25	0.794	1/8"	22.4	41.4	62
	EZWT12	0.273	0.15	0.19	0.23	0.27	0.39	0.47	0.61	0.72	0.87	1.06	1.22	1.50	0.794				
	EZWT18	0.410	0.23	0.29	0.34	0.42	0.58	0.71	0.92	1.09	1.30	1.59	1.83	2.25	1.19				
	EZWT20	0.456	0.25	0.32	0.38	0.46	0.65	0.79	1.02	1.21	1.44	1.77	2.04	2.50	1.59				
	EZWT27	0.615	0.34	0.44	0.52	0.62	0.87	1.07	1.38	1.63	1.95	2.38	2.75	3.37	1.19				
	EZWT35	0.798	0.44	0.56	0.67	0.80	1.13	1.38	1.78	2.11	2.52	3.09	3.57	4.37	1.59				
	EZWT40	0.912	0.50	0.65	0.76	0.91	1.29	1.58	2.04	2.41	2.88	3.53	4.08	4.99	1.98				
	EZWT42	0.957	0.52	0.68	0.80	0.96	1.35	1.66	2.14	2.53	3.03	3.71	4.28	5.24	1.59				
	EZWT48	1.09	0.60	0.77	0.92	1.09	1.55	1.89	2.45	2.89	3.46	4.24	4.89	5.99	1.59				
	EZWT50	1.14	0.62	0.81	0.95	1.14	1.61	1.97	2.55	3.01	3.60	4.41	5.10	6.24	1.98				
TO	EZWT53	1.21	0.66	0.85	1.01	1.21	1.71	2.09	2.70	3.20	3.82	4.68	5.40	6.62	1.98	1/4"	22.4	44.5	62
	EZWT60	1.37	0.75	0.97	1.14	1.37	1.93	2.37	3.06	3.62	4.32	5.30	6.11	7.49	2.38				
	EZWT68	1.55	0.85	1.10	1.30	1.55	2.19	2.68	3.47	4.10	4.90	6.00	6.93	8.49	1.98				
	EZWT70	1.60	0.87	1.13	1.33	1.60	2.26	2.76	3.57	4.22	5.04	6.18	7.13	8.74	2.38				
	EZWT80	1.82	1.00	1.29	1.53	1.82	2.58	3.16	4.08	4.82	5.77	7.06	8.15	9.99	1.98				
	EZWT100	2.28	1.25	1.61	1.91	2.28	3.22	3.95	5.10	6.03	7.21	8.83	10.2	12.5	3.18				
	EZWT130	2.96	1.62	2.09	2.48	2.96	4.19	5.13	6.62	7.84	9.37	11.5	13.2	16.2	3.18				
	EZWT150	3.42	1.87	2.42	2.86	3.42	4.83	5.92	7.64	9.04	10.8	13.2	15.3	18.7	3.57				
	EZWT160	3.65	2.00	2.58	3.05	3.65	5.16	6.32	8.15	9.65	11.5	14.1	16.3	20.0	3.97				
	EZWT180	4.10	2.25	2.90	3.43	4.10	5.80	7.10	9.17	10.9	13.0	15.9	18.3	22.5	3.97				
1/2"	EZWT200	4.56	2.50	3.22	3.81	4.56	6.45	7.89	10.2	12.1	14.4	17.7	20.4	25.0	4.37	1/2"	22.4	47.5	82
	EZWT220	5.01	2.75	3.55	4.19	5.01	7.09	8.68	11.2	13.3	15.9	19.4	22.4	27.5	3.97				
	EZWT240	5.47	3.00	3.87	4.58	5.47	7.73	9.47	12.2	14.5	17.3	21.2	24.5	30.0	4.76				
	EZWT260	5.93	3.25	4.19	4.96	5.93	8.38	10.3	13.2	15.7	18.7	22.9	26.5	32.5	5.16				
	EZWT270	6.15	3.37	4.35	5.15	6.15	8.70	10.7	13.8	16.3	19.5	23.8	27.5	33.7	5.16				
	EZWT280	6.38	3.49	4.51	5.34	6.38	9.02	11.1	14.3	16.9	20.2	24.7	28.5	34.9	5.56				
	EZWT300	6.84	3.74	4.83	5.72	6.84	9.67	11.8	15.3	18.1	21.6	26.5	30.6	37.4	5.56				
	EZWT340	7.75	4.24	5.48	6.48	7.75	11.0	13.4	17.3	20.5	24.5	30.0	34.7	42.4	5.56				
	EZWT350	7.98	4.37	5.64	6.67	7.98	11.3	13.8	17.8	21.1	25.2	30.9	35.7	43.7	5.95				
	EZWT400	9.12	4.99	6.45	7.63	9.12	12.9	15.8	20.4	24.1	28.8	35.3	40.8	49.9	7.14				

$$\text{Flow Rate (l/min)} = K \sqrt{\text{bar}}$$

Standard Materials: 303 Stainless Steel, 316 Stainless Steel, Brass, Viton gaskets standard.



HOLLOW CONE

CALL 413-772-0846  
Call for the name of your nearest BETE representative.